

Installation instructions

Transport | Installation | Operation | Maintenance



Product line:	CondenserR134a, R404A,...
Model range description:	Condensers – radial; horizontal; vertical
Model range:	RVH/RVV

guntner.com/uk

Contents

1	Important basic information.....	5
1.1	Safety instructions.....	5
1.1.1	Observing the instructions.....	5
1.2	Importance of the EN 378 series of standards – refrigeration systems and heat pumps – safety-related and environmental requirements.....	5
1.3	Responsibilities.....	5
1.3.1	Manufacturer's responsibilities.....	5
1.3.2	Responsibilities of the system's installer.....	6
1.3.3	Owner or operator responsibilities.....	6
1.4	Legal note.....	7
1.5	Instructions.....	8
1.5.1	Scope.....	8
1.5.2	Set-up and other applicable documents.....	8
1.6	Conventions.....	8
1.6.1	Typographical conventions.....	8
1.6.2	List of abbreviations.....	8
1.7	Conventions for safety signs and notices.....	9
1.7.1	General safety symbols and their meanings in these instructions.....	9
1.7.2	Warning symbols and their meaning in these instructions.....	10
1.7.3	Prohibitory signs and their meaning in these instructions.....	10
1.7.4	Mandatory signs and their meaning in these instructions.....	11
2	Safety.....	12
2.1	Labelling on the unit.....	12
2.1.1	Safety signs on the unit.....	14
2.1.2	Labelling on the packaging.....	15
2.1.3	Other signs and notes on the unit or packaging.....	18
2.2	Basic safety notices.....	21
2.2.1	How to act in an emergency.....	21
2.2.2	Personnel, care requirements.....	22
2.3	Proper intended use.....	22
2.3.1	Use according to the intended purpose.....	22
2.3.2	Operating conditions.....	22
2.3.3	Improper use.....	23
2.4	Mechanical residual hazards.....	25
2.4.1	Fins, sharp unit corners and edges.....	25
2.4.2	Fans.....	26

2.5	Electrical residual hazards.....	26
2.6	Thermal residual hazards.....	27
2.6.1	Danger of burns.....	27
2.7	Residual hazards due to CFC/HFC refrigerants.....	27
2.8	Residual hazards caused by vibrations.....	29
2.9	Residual hazards caused by pressurised parts.....	29
2.10	Residual hazards caused by defective installation.....	30
2.11	Residual hazards with break during operation.....	31
2.12	Residual risks due to ejected parts and liquids ().....	32
2.13	Residual hazards with disposal.....	32
3	Technical data.....	34
3.1	Heat exchanger (typical values).....	34
3.2	Fans.....	34
4	Set-up and function.....	36
5	Fan motor.....	37
6	Transportation and storage.....	39
6.1	Safety.....	39
6.2	Transportation and storage.....	39
6.3	Storage before installation.....	40
7	Set-up and start-up.....	41
7.1	Safety.....	41
7.1.1	Safety instructions for set-up and start-up.....	41
7.1.2	System-side safety requirements.....	43
7.1.3	Customer-side safety precautions.....	44
7.2	Requirements as regards the place of installation.....	45
7.3	Unpacking the unit.....	45
7.4	Installation.....	46
7.4.1	System-side requirements for stress-free installation.....	46
7.5	Notes on connecting the unit.....	47
7.5.1	Connect the unit to the system.....	48
7.5.2	Unit electrical connection and protection.....	48
7.6	Perform acceptance test.....	49
7.7	Test readiness for operation.....	50
7.8	Putting the unit into operation for the first time.....	50
8	Operation.....	52
8.1	Safety.....	52
8.2	Putting the unit into operation.....	52
8.3	Taking the unit out of operation.....	53
8.3.1	Shutdown, dismantling and disposal.....	53

	8.4	Shutting the unit down.....	54
	8.5	Putting the unit into operation after a shutdown.....	54
	8.6	Changing the unit over to another working fluid.....	55
9		Troubleshooting.....	56
	9.1	Safety.....	56
	9.2	Service.....	56
	9.3	Troubleshooting table.....	56
10		Maintenance.....	57
	10.1	Safety.....	57
	10.1.1	Before starting all maintenance.....	57
	10.1.2	With all maintenance work.....	58
	10.1.3	After all maintenance work.....	59
	10.2	Inspection and maintenance plan.....	59
	10.2.1	Fans.....	60
	10.2.2	Coil of the unit (heat exchanger).....	60
	10.3	Maintenance work.....	61
	10.3.1	Remove leaks.....	61
	10.4	Clean unit.....	61
	10.4.1	General.....	61
	10.4.2	clean the coil.....	62
	10.4.3	Cleaning fans.....	64
11		Plans/diagrams.....	65
	11.1	Electrics documentation.....	65
	11.1.1	Fan motor connection diagram.....	65

1 Important basic information

1.1 Safety instructions

1.1.1 Observing the instructions

WARNING

Being unaware of, or failing to acknowledge, the basic safety instructions and the safety regulations for handling and operating this unit can result in severe injury and damage to property.

- ▶ Always keep the instructions in the unit's immediate vicinity at all times.
- ▶ Ensure that the instructions are accessible to all people that have anything at all to do with the unit at all times.
- ▶ Ensure that the instructions are read and understood by all people that have anything at all to do with the unit.

1.2 Importance of the EN 378 series of standards – refrigeration systems and heat pumps – safety-related and environmental requirements

EN 378 deals with safety-related and environmental requirements for designing, constructing, producing, installing, operating, maintaining and disposing of refrigeration systems and cooling equipment.

EN 378 is oriented towards manufacturers, installers and operators of refrigeration systems and cooling equipment (see section 1.2. Responsibilities).

The objective of EN 378 is to restrict the possible hazards of refrigeration systems, cooling equipment and their working fluids (refrigerants and coolants) for people, property and the environment to a minimum.

Insufficient safety measures or non-compliance with safety-relevant regulations can result in:

- Breaks or ruptures on components with the danger of escaping materials (hazards caused by the influence of low temperatures, excess pressure, direct influence of the fluid phase, moving machine parts).
- Escaping working fluid after a break or leak because of defective design, improper operation, insufficient maintenance, repairs, filling and disposal (hazards caused by oxygen deficiency, flammability, frostbite, suffocation, panic)

1.3 Responsibilities

1.3.1 Manufacturer's responsibilities

The notes provided in these instructions on maintaining the unit's functional safety, on preventing possible hazards during transport, set-up and installation, start-up and operation as well as maintenance activities (cleaning, servicing and repairing) refer exclusively to the unit.

The manufacturer's responsibilities are documented in the unit's version in acc. with EN 378-2 (design, manufacture and testing).

The working fluid-carrying parts of the unit (core tubes, distributor tube and header outlet) are configured so that they remain tight with the foreseeable mechanical, thermal and chemical stresses, and withstand the maximum permissible operating pressure.

Material, wall thickness, tensile strength, corrosive resistance, shaping process and testing are suitable for the working fluid used and withstand the possible pressures and stresses that might occur.

All responsibility for the equipment into which the unit is integrated, are the exclusive responsibility of the people involved in the individual workflows.

1.3.2 Responsibilities of the system's installer

The responsibilities of the system installer are documented in the system's version (design, manufacture and testing – in accordance with EN 378-2).

Interfaces between component supplier – installer of the system:

- Güntner GmbH & Co. KG In the event of a fault:
In the event of problems during set-up, installation, start-up and operation, immediately contact Güntner GmbH & Co. KG.

The responsibilities of the system installer in particular include:

- Planning and preparing emergency measures:
To avoid consequential damage caused by operational disruptions, a warning system which immediately signals all faults must be provided on-site. Prepare emergency measures that prevent consequential damage for people and property should faults occur.
- Specify checking and maintenance intervals:
The system must be configured and equipped with all required equipment for maintenance and sufficient servicing and testing in accordance with EN 378-4.

When the unit is integrated into the refrigeration system, the unit's working fluid and version must not deviate from the order-related information specified in the order-related documents.

The installer of the system must refer to the requirement for sufficient instruction of the operating and supervision staff when operating and maintaining the equipment.

It is recommended that the future customer staff – if possible – be present during the set-up and installation, for tightness tests and cleaning, while the system is being filled with working fluid and for the adjustment of the equipment.

1.3.3 Owner or operator responsibilities

The owner or operator responsibilities are documented in the operation, maintenance, servicing and recovery of the system in accordance with EN 378-4.

The owner or operator must ensure that the proper people are sufficiently trained and qualified for operating, monitoring and servicing the system.

The operating personnel for the system must have sufficient knowledge and experience with regard to the mode of operation, operation and daily monitoring of this system.

Before starting up the system the owner or operator must ensure that the operating personnel are adequately instructed about the system's documentation (which these instructions belong to) on the set-up, monitoring, mode of operation and maintenance of the system and about

the safety measures to be observed as well as the properties and handling of the working fluid to be used.

The owner or operator must ensure that when operating, monitoring and maintaining the system the working fluid and version must not deviate from the details specified in the order-related documents.

Planning and preparing emergency measures: To avoid consequential damage caused by operational disruptions, a warning system must be installed on the customer's premises. Prepare emergency measures that prevent consequential damage for people and property should faults occur.

Responsibility remains with the owner or operator of the system, if the system is used by anybody else, unless there is a contrary agreement on sharing responsibility.

If you operate units that are wetted or sprayed with water, you must observe the contents of the VDI guideline 2047-2 "Requirements for the hygienic operation of cooling towers", the specifications of the 42nd BImSchV (Federal Immission Control Ordinance) and the VD-MA leaflet "Notes and recommendations for operating and maintaining evaporation cooling plants" ("Hinweise und Empfehlungen zum Betrieb und zur Wartung von Verdunstungskühlanlagen").

1.4 Legal note

Note that warranty claims require the existence of a defect that must be proved. These installation instructions are part of the unit and must be observed in their entirety. Damage and malfunctions resulting from the failure to comply with the installation instructions are not covered by the warranty. This applies in particular to the use of spare parts other than those specified (original spare parts in case of doubt) and modifications to the unit compared to its original condition on delivery without the consent of Güntner GmbH & Co. KG. Modifications in this sense are, in particular, the use of working fluids other than those specified, changes to the operating parameters and mechanical changes such as metal-cutting operations (e.g. drilling) without sufficient protection of the unit from the chips produced.

1.5 Instructions

1.5.1 Scope

These instructions apply to condensers in the model range RVH/RVV.

The units are components of a system, e.g. for conditioning and circulating the room air in storage rooms

NOTICE

You will find the precise type of your unit in the attached order-related documents.

1.5.2 Set-up and other applicable documents

The following documents are applicable:

- These instructions, in particular the information on:
 - Intended use
 - Installation and operation
 - Safety instructions and warnings
 - Technical data
- Connection diagram inside the terminal box
- For further technical data, see nameplate

These instructions are part of the operating instructions of the plant provided by the installer of the plant .

1.6 Conventions

1.6.1 Typographical conventions

The following text markups are used in these instructions:

Bold	Requires special attention!
Grey triangle	Instructions

1.6.2 List of abbreviations

Abbreviations	Meaning
CFC/HFC	Alkane group refrigerant, e.g. R134a, R404A, R407C, ...
EN 378	European Norm 378: Refrigeration systems and heat pumps; safety-related and environmental requirements
EN	European Norm

Abbreviations	Meaning
DIN	German industrial standard (specification of a standard)
ISO	International Standardization Organization .
°C	Degrees Celsius (Celsius scale temperature)
bar	Unit of pressure
l	Litre (liquid volume)
Vol%	Volume percent (concentration level relative to a volume)
IP	Insulation protection
Q 6,3	Balancing quality
ppm	parts per million, concentration figure, stands for "millionth part"
Hz	Hertz (frequency)
D	Delta connection (alternating current: high speed)
S	Star connection (alternating current: low speed)
3~	3-phase current
1~	1-phase alternating current
VDE	"Verband der Elektrotechnik, Elektronik und Informationstechnik" (Association for Electrical, Electronic & Information Technologies)
TCC	Technical Connection Conditions
EPC	Electric Power Company
VDI	"Verein Deutscher Ingenieure" (German engineers' association)

1.7 Conventions for safety signs and notices

1.7.1 General safety symbols and their meanings in these instructions

⚠ DANGER
Dangerous situation that will definitely cause serious injury or death if it is not avoided.
⚠ WARNING
Dangerous situation that could cause serious injury or death if it is not avoided.
⚠ CAUTION
Dangerous situation that could cause slight to moderate injury if it is not avoided.
NOTICE
Refers you to possible damage to property.

1.7.2 Warning symbols and their meaning in these instructions



Warns against hand injuries!

Failure to comply with warnings may result in hands or fingers being crushed, dragged in or otherwise injured.



Warns against hot surfaces!

The temperature is over +45°C (at which protein clots) and can cause burns.



Warns against dangerous electrical voltage!

Danger of an electric shock if voltage-carrying parts are touched.



Warns against fire-risk substances at set-up point.

Use of ignition sources can cause fire at set-up point.



Warns against harmful to health or irritant substances at set-up point

Contact with or inhaling substances that are irritant or harmful to health can cause injuries or damage peoples' health.



Warning of automatic start-up

If the unit starts up automatically during maintenance work there is a danger of pinching/trapping the hands and fingers.

1.7.3 Prohibitory signs and their meaning in these instructions



Fire, open fire and smoking prohibited!

Ignition sources must be kept away and ignition sources must not develop!



No smoking!

Smoking is forbidden.



No entry!

It is prohibited to enter the marked area.

1.7.4 Mandatory signs and their meaning in these instructions



Use eye protection!

Eye protection: Use protective cover, protective glasses or face protection.



Use hand protection!

Protective gloves must protect against mechanical and chemical dangers (see imprinted pictograms).



Use respiratory protection!

Breathing apparatus must be suitable for the working fluid used. Breathing apparatus must consist of:

- At least two independent breathing devices (self-contained breathing apparatus)



Use protective clothing!

Personal protective clothing must be suitable for the working fluid used and for low temperatures, and must have good heat insulation properties.



Disconnect prior to work!

Disconnect the electrical system and secure against switching on again before starting installation, maintenance and repair work.

2 Safety

2.1 Labelling on the unit

Position of the labels on the unit

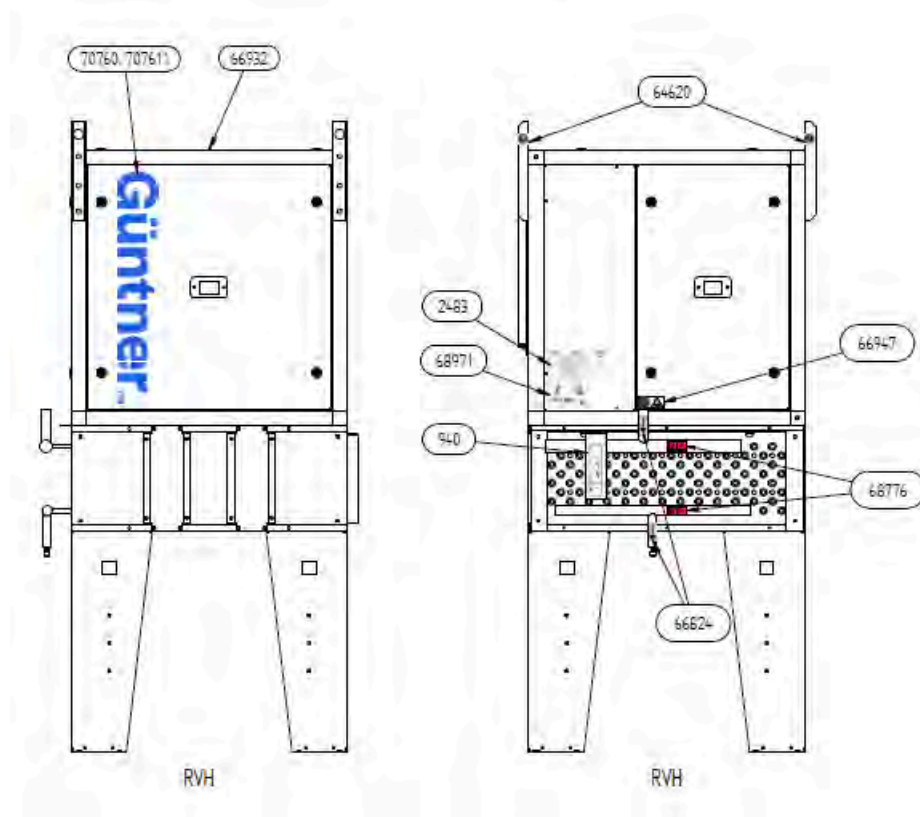

Labels on the RVH

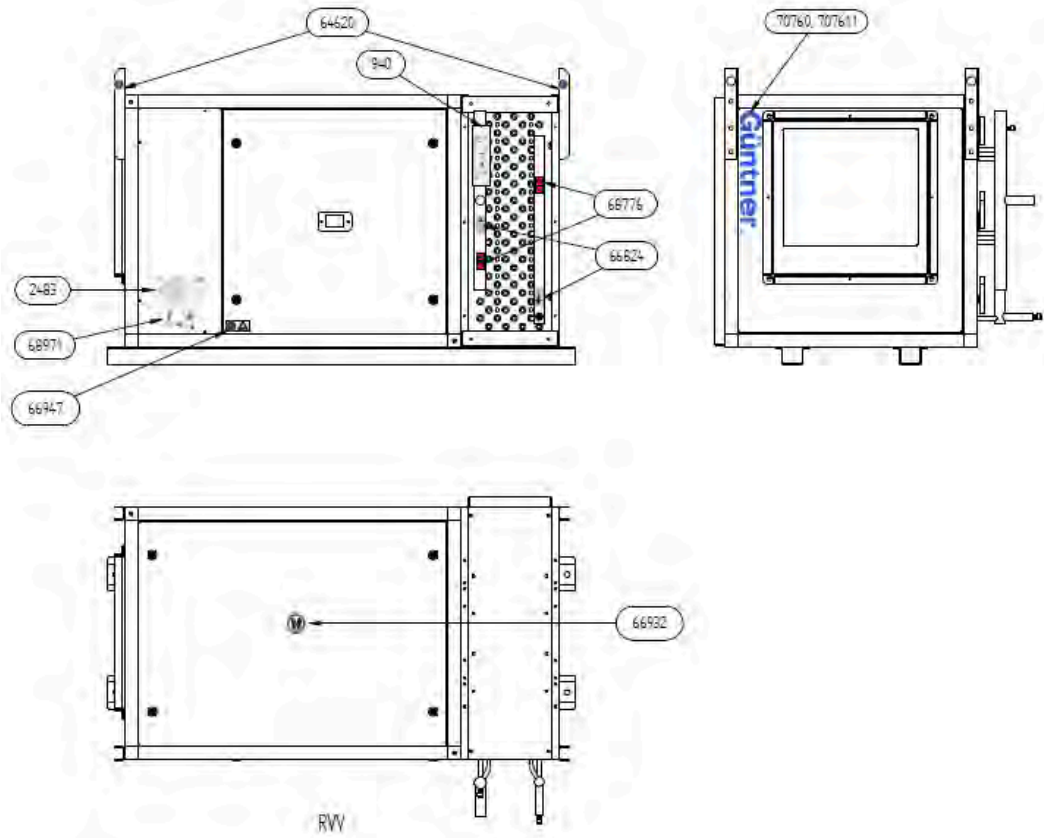

Labels on the RVV

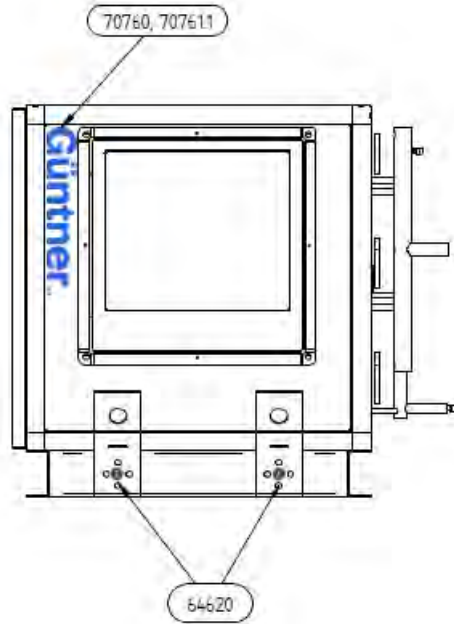

Labels on the RVV (base frame)

2.1.1 Safety signs on the unit

Safety signs on the unit individually:



940 – Warning "Transport filling" on the Schrader valve



66947 – Mandatory sign/warning sign: Completely disconnect/warning of hand injury



64620 - Lifting point



60325, 68776 – Warning "Do not load. Do not lift."

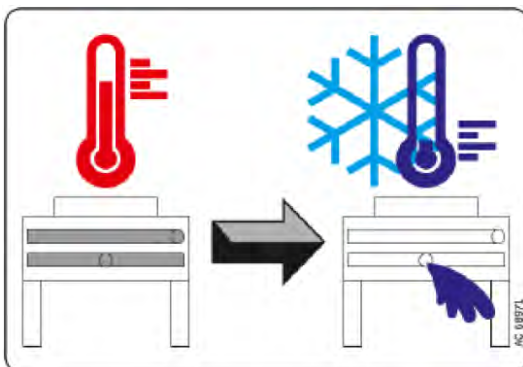

68971 – Danger of frost for dry coolers in general (only for dry coolers/flange connection)



5206599 – Warning "Voltage" (for electrical attachments)



3872 – Earthing marking



66932 – Warning "No stepping onto the surface"

2.1.2 Labelling on the packaging

Labels on the packaging

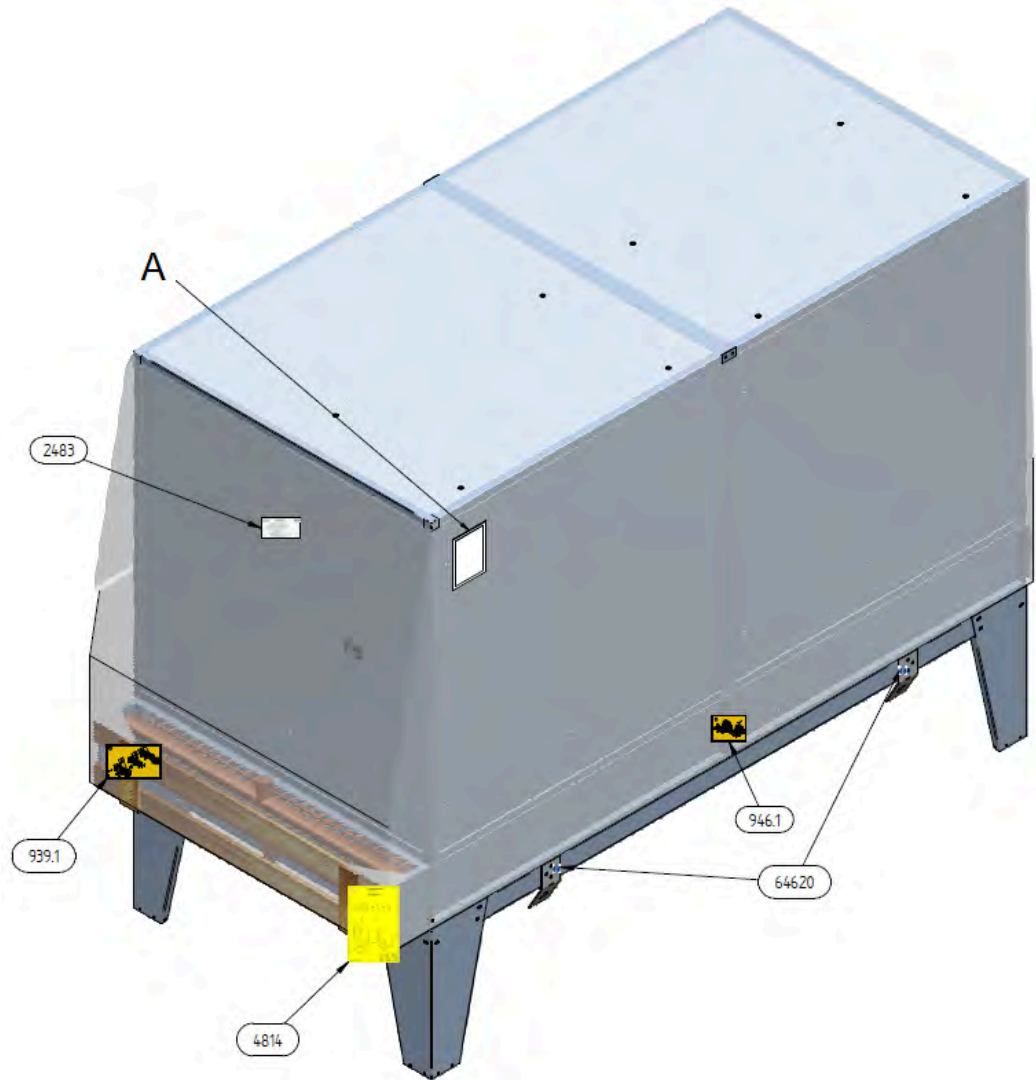

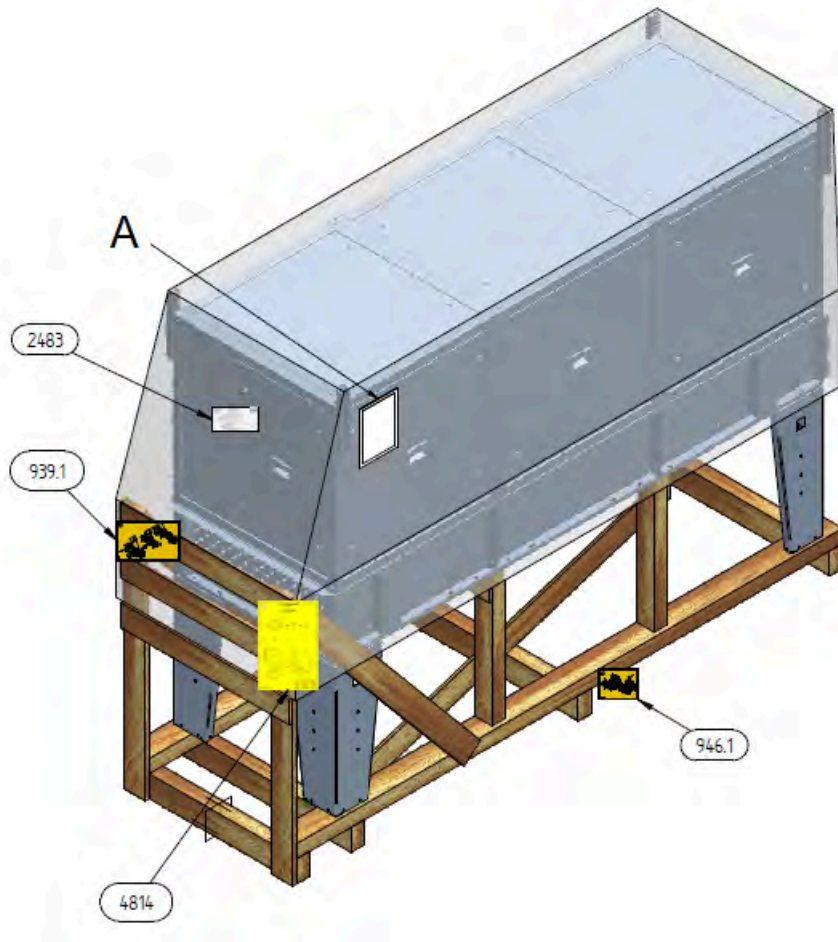

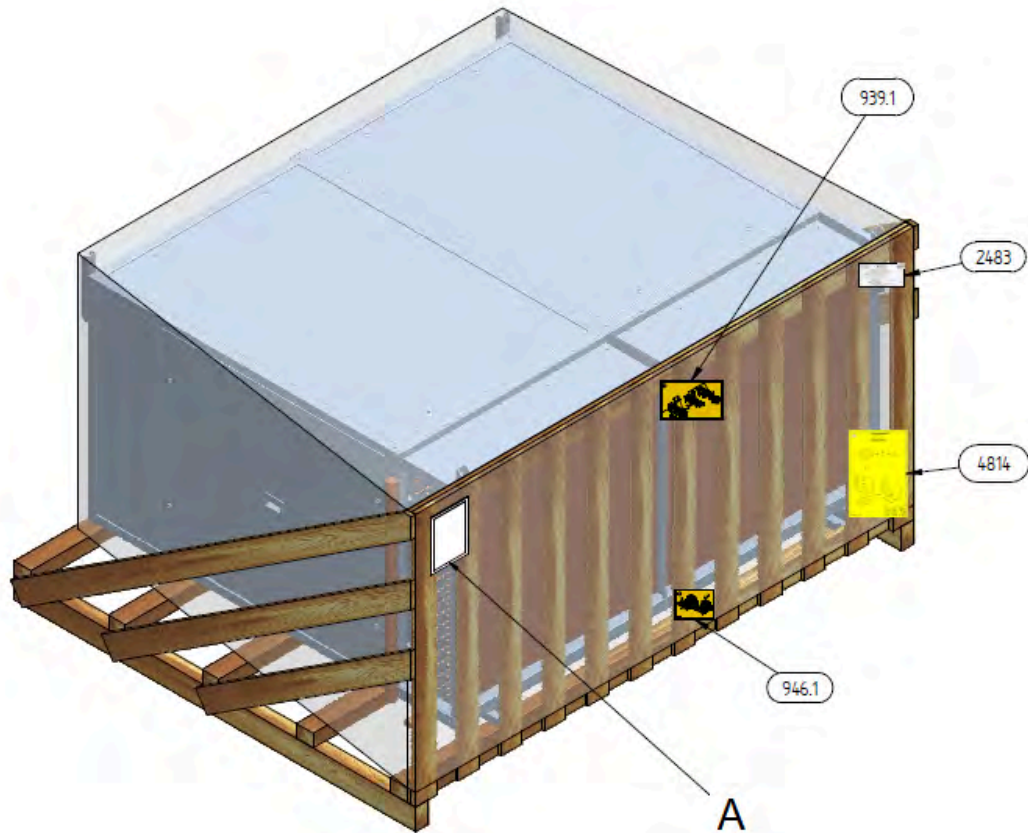



Packaging

A - Intralogistics sign

2.1.3 Other signs and notes on the unit or packaging

Güntner GmbH & Co.KG Hans-Güntner-Straße 2-6 82256 Fürstenfeldbruck www.guentner.de		 0036 PED *  II 2G IIB T4			
Projektnummer - Project number	101014529				
Gerätebezeichnung - Unit name	GVH 100.3B/2x4-L(S).E				
Gerät Seriennummer - Device serial number	404157434/52.00042				
Ventilator / ID / Drehzahl - Fan / ID / Speed	VT01407 / 2008 / 480 min -1				
Umgebungstemperatur - Air ambient temperature	-30°C / +50°C				
Herstellungsjahr - Year of manufacture	2015				
*Druckgerät Seriennr. - pressure equipment serial no.	404157435/52.02100				
Volumen - Volume (V)	297.5 l				
Max. zulässiger Druck (PS) Max. allowable pressure (PS)	32 / 0 bar	24 / 0 bar	0 / -1 bar		
Zulässige min./ max. Temperatur (TS) Allowable min./ max. temperature (TS)	-10°C / +100°C	-50°C / -10°C	-5°C / +40°C		
Prüfdruck (PT) / Prüfmedium Test pressure (PT) / Test medium	35,2 bar / Druckluft - Compressed air				
Prüfdatum - Test date	15.02.2015				
Fluidgruppe / Zustand - Group of fluid / State	2 / gasförmig - gaseous				

2483 - Example of a nameplate

Güntner™

706**, 2118, 2119 – Güntner logo



66824 and 68909 - Connections IN and OUT

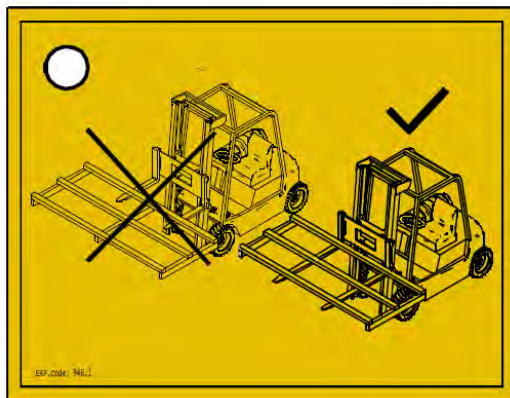

946.1 - Fork-lift transport

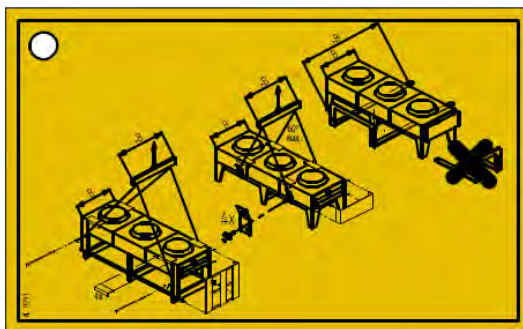

939.1 - Transport regulation



70274 - Only for transport

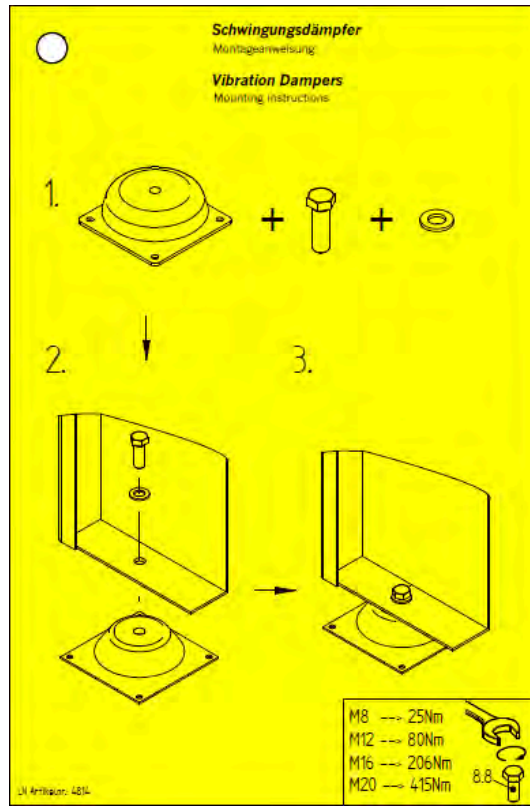

4814 - Vibration damper



64620 - Lifting point

2.2 Basic safety notices

2.2.1 How to act in an emergency

WARNING

Danger of injuries!

The FC/HFC refrigerants R-134a, R-404A, R-407C, ... used are refrigerants of group L1/A1 in acc. with the classification by flammability (L) and toxicity (A) in acc. with EN 378-1. This corresponds to fluid group 2 in acc. with the Pressure Equipment Directive 2014/68/EU (for the United Kingdom: PE(S)R 2016):

- Refrigerants that, when gaseous, are non-flammable irrelevant of their concentration in air.
- Refrigerants with a time-weighted, averaged concentration that have no adverse effects on the majority of staff that are exposed every day during a normal 8 hour working day and a 40 hour working week to this concentration, which is greater than or equal to 400 ml/m³ (400 ppm (V/V)).

There is no imminent danger for the staff. However, refrigerants of the Group L1/A1 are generally heavier than air and may flow off to rooms on a lower level. In still air there may be an increase of the ground level concentration. With high concentrations there is a danger of suffering from disordered cardiac rhythm and suffocation due to a reduced oxygen concentration, especially at ground level.

Unauthorised people must not have access to the unit. Please ensure that the CFC/HFC refrigerant escaping from the unit cannot penetrate the interior of the building or put people at risk in any other way.

Safety measures and procedure:

- In the event of serious unexpected leakage of refrigerant, activate the emergency measures provided, e.g. if:
 - Visibly escaping refrigerant liquid or vapour from the heat exchanger or pipe components.
 - there is a sizeable sudden escape (escape and evaporation of the greater part of the entire refrigerant filling within a short time, e.g. in less than 5 minutes);
 - Activation of the refrigerant detector (limit value in accordance with EN 378-1; Annex E):
- Have experienced, trained personnel with prescribed protective clothing perform all necessary protective and other measures:
 - Use respiratory protection.
 - Use a self-contained breathing apparatus for repair work in areas with high refrigerant concentrations in the ambient air.
 - Divert escaped refrigerant vapour and escaped refrigerant liquid safely.
 - Ensure that no refrigerant enters water systems or sewage.

2.2.2 Personnel, care requirements

⚠ CAUTION

The unit may be installed, put into operation, operated, maintained and repaired only by trained, experienced and qualified personnel. In order to be considered qualified, people who are to be responsible for the operation, maintenance, repair and evaluation of systems and their components must have the necessary training and specialist knowledge for such work, as stipulated in EN 378-1. Qualified or expert means the ability to satisfactorily perform the activities required for the operation, maintenance, repair and evaluation of refrigeration systems and their components.

The unit may be operated by operating personnel that have no specific knowledge of refrigeration engineering, but have sufficient knowledge and experience with regard to the mode of operation, operation and daily monitoring of this system, . This operating personnel may not make any interventions or settings on the system.

Changes to the unit, which the manufacturer has first agreed to in writing, may only be made by the instructed and qualified personnel.

Electrical installation:

Work on the electrical equipment may only be performed by personnel that have the required expertise (e.g. an electrician or an electro-technically instructed person), and who are authorised by the operator, in compliance with the respective VDE regulations (and national and international provisions) and the TCCs of the EPCs.

2.3 Proper intended use

2.3.1 Use according to the intended purpose

Condensers of the RVH/RVV series are heat exchangers for indoor installation. Condensers liquefy the refrigerant by dissipating heat to the air that is guided over the dry heat transfer surface by fans.

The unit is delivered for operation with a specific operating point:

- Condensation temperature
- Airflow volume
- Air inlet temperature
- Relative air humidity.

The specified operating point is given in the order-related documents.

2.3.2 Operating conditions

The unit is a component of a plant including its working fluid circuit. The purpose of these instructions, as part of the operating instructions of the plant is to minimise the potential hazards to persons, property and the environment from the unit and the working fluid used in it. These hazards are essentially connected with the physical and chemical properties of the working fluid and with the pressures and temperatures that occur in the working fluid-carrying components of the unit see "Residual hazards due to CFC/HFC refrigerants", page 27.

⚠ WARNING

Danger of injuries and damage to property!

The unit must be used only in accordance with the proper intended use. The operator must ensure that when operating, monitoring and maintaining the unit, the fluid and unit type do not deviate from the order-specific information specified in the order documents.

The operator must ensure that maintenance measures are performed in compliance with the operating instructions of the plant.

Filling the unit with a different fluid is permitted only following written approval by the manufacturer. You will find the order-related proper use as intended in the order-specific documents.

Do not exceed the max. operating pressure given on the unit's type plate.

2.3.3 Improper use

General

The unit is being used improperly if:

- An unspecified working fluid, an unspecified pressure and/or an unspecified temperature are used,
- The unit is not disconnected from the mains for cleaning/maintenance purposes,
- The supply line (electric) is fused or dimensioned incorrectly by the customer.
- The unit is operated in an environment or for capacity requirements (e.g. aggressive/corrosive environment; capacity range) the unit with its material combination or capacity is not designed for, or which do not correspond to the intended use.

⚠ WARNING

Danger of injuries and damage to property!

Working fluids and their combinations with water or other substances in the working fluid-carrying components have chemical and physical effects from the inside on the materials surrounding them. The unit may be pressurised only with CFC/HFC refrigerant. Operating the unit with other working fluids would have the effect that

- the material, wall thickness, tensile strength, toughness, corrosion resistance, shaping process and tests performed at the factory are not suitable for other working fluids and cannot withstand the pressures and stresses that may occur,
- the unit would not be resistant to the other working fluid and the combination of the other working fluid,
- the unit may not remain tight during operation and when shut down and
- a possible sudden escape of working fluids could directly endanger people and/or property and the environment.

The maximum permissible operating temperature specified on the type plate must not be exceeded! If the operating temperature is exceeded,

- the unit would be exposed to an impermissibly high pressure (pressure/temperature correlation),
- signs of material fatigue would emerge,

The maximum permissible operating pressure specified on the type plate must not be exceeded! If the operating pressure is exceeded,

- the parts of the unit carrying the working fluid might not withstand the foreseeable mechanical, thermal and chemical stresses and the pressures that may occur during operation and when shut down,
- the unit would not remain tight during operation and when shut down,
- there may be a possible sudden escaping of working fluids after a break or leakage on working fluid-carrying components, which would result in the following dangers:
 - Hazard due to ejected materials,
 - Dangers caused by oxygen displacement
 - Fire hazard (caused by refrigerator oil parts)
 - danger of frostbite (caused by liquid coolant squirting/splashing),
 - Suffocation hazard
 - hazards caused by panic reactions,
 - Environmental pollution

⚠ WARNING

FC/HFCCondenserDry coolers must not be used

- where it is possible that short or prolonged effect caused by contact, inhalation or ingestion of the working fluid might result in harmful hazards.
- where it is possible that a sudden major release (release and evaporation) of the greater part of the entire working fluid charge occurs in a short time (e.g. in less than 5 minutes).

The unit must not be modified without prior written consent of Güntner GmbH & Co. KG. Modifications to the unit are:

- Changing the operating point (in accordance with section see "Heat exchanger (typical values)", page 34)
- Changing the fan capacity (air volume)
- Changing the volume of working fluid flowing through
- Changing over to another working fluid
- Changeover of the originally designed defrost technology (if any)

The unit must not be operated if safety devices recommended by the manufacturer are not available, not properly installed or not fully functional.

The unit must not be operated if it is damaged or shows signs of faults. All damage and faults must be reported to Güntner GmbH & Co. KG immediately and must be rectified without delay.

Work on the unit must not be performed without the personal protective equipment prescribed in these instructions.

2.4 Mechanical residual hazards

2.4.1 Fins, sharp unit corners and edges

⚠ WARNING





Warns against hand injuries!
Danger of cuts to hands and fingers on the fins and on sharp edges and corners of the unit.



Use reliable hand protection!

2.4.2 Fans

⚠ WARNING





Danger of cutting off, pulling in!
There is a danger of cutting off fingers on the rotating fan blades, injury hazard for the hands and pulling in danger for loose elements such as hair, necklaces or clothing parts.

Do not operate fans without guard grille. Pinch/trap point hazard!
With automatic fan start during maintenance work there is a danger of pinching/trapping for the hands and fingers.

Power off the unit before you begin maintenance work with which you must remove the guard grille. Secure the unit against unintentional switching on again by removing the electric fuses for the unit. Secure the unit with a suitable warning sign referring to unintentional switching on.

2.5 Electrical residual hazards

⚠ WARNING



Warns against dangerous electrical voltage!
Direct and indirect contact with voltage-carrying components such as motors and electrical lines can cause serious injuries or death.

Power off the unit before you begin maintenance work. See the refrigeration system's system documentation for this. Secure the unit against unintentional switching on again by removing the electric fuses for the unit. Secure the unit with a suitable warning sign referring to unintentional switching on.



Please note that the mains cables may also be carrying voltage, even if the unit is powered off.

Work on electrical equipment may be performed only by people that have the required expertise (e.g. an electrician or an electro-technically instructed person) and who are authorised to do so by the operator.

2.6 Thermal residual hazards

2.6.1 Danger of burns

⚠ WARNING

Warns against hot surfaces!
With refrigerant temperatures over +45 °C there is the hazard of burns on tube components and distribution tubes.
Use hand protection!

2.7 Residual hazards due to CFC/HFC refrigerants

The FC/HFC refrigerants R-134a, R-404A, R-407C, R-507 ... used are refrigerants of group L1/A1 in acc. with the classification by flammability (L) and toxicity (A) in acc. with EN 378-1. This corresponds to fluid group 2 in acc. with the Pressure Equipment Directive 2014/68/EU (for the United Kingdom: PE(S)R 2016):

- Refrigerants that, when gaseous, are non-flammable irrelevant of their concentration in air.
- Refrigerants with a time-weighted, averaged concentration that have no adverse effects on the majority of staff that are exposed every day during a normal 8 hour working day and a 40 hour working week to this concentration, which is greater than or equal to 400 ml/m³ (400 ppm (V/V)).

There is no imminent danger for the staff. With good air ventilation and removal by suction, it will fall easily and clearly below the allowed limit values.

⚠ WARNING

Danger of harm to health and environmental damage!

Refrigerants of the Group L1/A1 are generally heavier than air and can flow off to rooms on a lower level. In still air, there can be an increase of the ground level concentration. With high concentrations, there is a risk of cardiac arrhythmia and suffocation due to a reduced oxygen concentration, especially at ground level.

- Unauthorised people must not have access to the unit.
- Ensure working rooms are well-ventilated in order to prevent inhalation of high vapour concentrations.
- Please ensure that the CFC/HFC refrigerant escaping from the unit cannot penetrate the interior of the building or put people at risk in any other way. CFC/HFC refrigerant vapour or gas must be kept from penetrating neighbouring rooms, staircases, yards, passages or drainage systems and must be discharged without risk
- Monitor the CFC/HFC refrigerant concentration in the ambient air to ensure constant compliance with limit values.
- Check the leak tightness of the unit regularly as described in these instructions (see "Inspection and maintenance plan", page 59).



Ignition and fire hazard!

- With work involving fire or sparks, e.g. grinding, welding, etc., ensure suitable fire fighting equipment is on-site.
- In particular be aware of the danger of ignition of unintentionally carried in oil residues or CFC/HFC refrigerant.
- Ensure that the provided fire fighting equipment is provided in sufficient quantities, that it functions properly and that the extinguishing agent does not react with the CFC/HFC refrigerant.
- Smoke during work is forbidden!



Frostbite hazard

Splashes of CFC/HFC refrigerant that is superheated can cause frostbite to the eyes and skin.

- When removing faults after spills of CFC/HFC refrigerant, you must be vigilant for any remaining superheated CFC/HFC refrigerant.



Danger of poisoning!

CFC/HFC refrigerant contact with fire can form toxic combustion products.

- Prevent CFC/HFC refrigerant contact with open fire.
- Welding and soldering may therefore take place only after completely draining the relevant section of the system of the CFC/HFC refrigerant. Ensure good ventilation here!
- Be sure to wear a self-contained breathing apparatus for emergency work in areas with high FC/HFC refrigerant concentrations in the ambient air.



2.8 Residual hazards caused by vibrations

⚠ WARNING

Danger of injuries and damage to property caused by escaping materials

If fans are damaged during fan operation, flying parts of the fan blades can injure people or cause damage to property close to the fan.

Fans, units and pipes in the system must be designed, manufactured and integrated in such a way that risks due to vibrations generated by them or other parts of the system are reduced to the lowest possible level – using all available means to reduce vibrations, especially at the source.

NOTICE

Damage to property caused by vibrations

Vibrations that are increased by imbalances, as created by dirt or fan blade damage, are regularly caused with fan operation. The vibrations are transferred to the unit, where they can cause damage and damage the unit mounting or refrigeration system components connected to the unit.

Regularly check the fan blades and protection guards for dirt and make sure the fans run smoothly (see "Fans", page 60).

2.9 Residual hazards caused by pressurised parts

⚠ WARNING

Injury and damage to property caused by pressurised parts that contain CFC/HFC refrigerant!

Breaks in pressurised pipes or pressurised components of the unit can cause injuries or damage to property caused by escaping materials. A sudden large release of the working fluid with its hazardous properties after a break or leak on pressurised components of the unit can cause the following hazards:

- Oxygen displacement
- Flammability caused by proportion of lubricating oil for refrigerating compressors present
- Frostbite (caused by liquid refrigerant squirting/splashing)
- Suffocation
- Panic,
- Environmental pollution

Ensure that the unit in question is pressure-free before maintenance work begins or remove the working fluid from the unit in question.

2.10 Residual hazards caused by defective installation

WARNING

Injuries and damage to property caused by defective installation!

Defective installation results in hazards caused by:

- Break or leak on liquid-carrying unit components and pipes
- Absence of release devices to prevent liquid escape: Liquid that can heat up during a refrigeration system shutdown state and cause pipes or connection flanges to break when it expands must not be locked in.
- Uneven load distribution on the fixtures with the danger of stresses within the unit or unit displacement (breaks or leaks on fluid-carrying components of the unit and pipes; danger of breaking off).
- Insufficient securing of working fluid-carrying lines against mechanical damage! On-site connections: loaded installation; effect of forces on the distribution and header pipes with the danger of breaks or leaks on fluid-carrying components of the unit and pipes; danger of breaking off!
- Break-off and fall danger of the unit with hazard of escaping working fluid and exposed electrical cables.
- Danger of damage caused by environment-conditional hazard sources (production, transport and other processes at the set-up point).
- Unit functional faults caused by air inlet/outlet obstructions.
- Obstruction of all-side inspection, checks and maintenance, i.e. no unobstructed accessibility to the working fluid-carrying and electrical components, connections and cables, no recognisable identifiers on the pipes and insufficient space for tests.

Ensure that:

- The units are to be installed on the fixing points corresponding with their weights and tightened with fixing bolts. The operator or installer is responsible for ensuring that the bolted connections are of an adequate strength.
- The diameters of the mounting holes have been statically determined by the manufacturer and the fixing bolts are adapted accordingly.
- The fixing bolts are secured against loosening by means of an appropriate locking device.
- The fixing bolts are not overtightened or stripped.
- All fixing bolts are tightened equally to achieve a load distribution on the connections that is as balanced as possible.
- All fixing points maintain the same spacing to the fixing level permanently and under load, so that no mechanical stress occurs in the unit structure. The units are anchored in their fixing position in order to prevent the equipment from moving.
- The functional safety of the fixing bolts is tested as part of the maintenance periods. see "Maintenance", page 57,
- The unit is fixed and set up so that it is not damaged by environment-conditional hazard sources (production, transport and other processes at the set-up point) or its functioning is not disturbed by the interventions of unauthorised persons.
- The units are fixed and set up so that unobstructed air inlet/outlet is constantly available without any air short circuiting.
- The units are fixed so that they can be inspected, checked and maintained from all sides at all times, i.e. there must be unobstructed access to the refrigerant-carrying and electrical components, connections and lines, the pipeline labelling must be identifiable and adequate space must be available for testing.
- The working fluid-carrying lines must be protected against mechanical damage. On-site connections: when installing keep the unit free of load; force must not be exerted on the distribution and header pipes.

- The following must be observed without fail when installing the unit:
 - Imperative adherence to spacing from objects that could be endangered by an effect of the CFC/HFC refrigerant.
 - Provision of measures to safeguard protective objects from a CFC/HFC refrigerant concentration higher than that permitted by EN 378-3.
 - Easily flammable materials must not be placed below the unit.
 - Set up and fix units as follows: In areas that are used for inner-plant traffic, the pipelines to and from the unit must be installed only with connections and fittings that cannot be removed.
 - Release devices to prevent liquid escapes must be provided and available.
 - Subcooled liquid may be present in only the lowest possible amount in system sections in shutdown state – minimized number of “fluid sacks”.

2.11 Residual hazards with break during operation

WARNING

Injuries and damage to property caused by break during operation!

- Incorrect installation (see "Residual hazards caused by defective installation", page 30),
- Failure to observe the maximum permissible operating pressure (see "Operating conditions", page 22)
- Failure to observe pressurised pipe sections during maintenance (see "Residual hazards caused by pressurised parts", page 29),
- Failure to observe the residual risks due to vibrations (see "Residual hazards caused by vibrations", page 29)

result in ruptures during operation and maintenance. This results in dangers caused by

- ejected materials (see "Residual hazards caused by pressurised parts", page 29),
- released working fluid (see "Residual hazards due to CFC/HFC refrigerants", page 27)

Ensure that:

- The installation is fault-free.
- The maximum permissible operating pressure is always adhered to.
- Pressurised line sections are de-pressurised before all maintenance and repair work.
- Vibrations, both from the refrigerating plant (vibrations caused by compressors, units and pipes of the plant as a whole) and from the fan (imbalances due to accumulation of dirt and damage) must be reduced to the lowest possible level using all available means.
- Release devices to prevent liquid escapes are provided and available.
- Undercooled liquid is only present in the lowest possible amount in system sections in shutdown state – minimized number of "fluid sacks".

2.12 Residual risks due to ejected parts and liquids ().

⚠ WARNING

Personal injury and damage to property caused by ejected parts and liquids!

Residual risks due to ejected parts and liquids (see "Residual hazards with break during operation", page 31).

2.13 Residual hazards with disposal

⚠ WARNING

Danger of injuries and damage to property caused by CFC/HFC working fluid !

The following notes are recommendations for the proper professional disposal of the unit. Applicable waste disposal laws are binding for the country of operation:

- Disposal must only be carried out by experts.
- All unit components, e.g. working fluids, refrigerator oil, heat exchangers, fans, must be disposed of properly as specified.
- Used working fluid that is not determined for reuse, must be treated as waste and safely disposed of. There must be no emissions into the environment.
- The CFC/HFC refrigerant must be filled into a special refrigerant container in compliance with the respective safety measures. This special refrigerant container must be suitable for the refrigerant. It must be easy to identify and labelled for the refrigerant, e.g. "HFC R-4304A recovered".
- A disposable single-use container must not be used, as refrigerant vapour residues in the container escape during disposal.
- The working liquid receiver must not be overfilled. The maximum permissible pressure of the working fluid container must not be exceeded during the work process.
- The working fluid must not be filled in a liquid container that contains another or an unknown working fluid. This other or unknown working fluid must not be released into the atmosphere, but rather identified, treated again, or properly disposed of as specified.
- An officially authorised facility can be used for destroying the working fluid.
- Used refrigerator oil that has been recovered from the unit and cannot be treated again, must be kept in a separate, suitable container, treated as waste and safely disposed of.
- It must be ensured that all unit components containing working fluids and refrigerator oil are disposed of properly as specified.
- The unit is made primarily of the basic materials aluminium, steel, galvanized steel (casing), copper, polyamides (electrical components), stainless steel, insulating material, (heating rods for electric defrosting, option, accessories at the customer's request). These materials can be handled by the waste industry, even in paint-treated state, and recycled via mechanical and thermal separation.
- Before scrapping the working fluid-carrying unit components must be drained, whereby the pressure must be reduced to at least 0.6 bar absolute for a unit pipe volume up to and including 200 l, and to 0.3 bar absolute for a unit pipe volume over 200 l. The pressure reduction process is then ended when the pressure no longer increases and remains constant, and the unit is at ambient temperature.

⚠ WARNING

Danger of environmental pollution!

The facility for recovering or disposing of the refrigerant must be operated so that the danger of a refrigerant or refrigerator oil emission into the environment is kept as low as possible.

- Ensure that no working fluid enters water systems or sewage.
- Operate the facility for recovering or disposing of working fluids so that the danger of a working fluid or refrigerator oil emission into the environment is kept as low as possible.

Güntner GmbH & Co. KG's transport packaging is made from environmentally compatible material and is suitable for recycling.

3 Technical data

3.1 Heat exchanger (typical values)

NOTICE

The typical values given here refer to standard types of this series. The following is valid especially for special equipment: Please observe the data in the calculation (Annex) and on the nameplate.

NOTICE

The capacity values of the fans depend on the ambient temperature and the air resistance at the place of installation.
All electrical parts must be installed in accordance with EN standards.

Project number	See order documents
Unit name	See order documents
Manufacturer number	See order documents
Production year	See order documents
Working fluid	See order documents
Volume	See order documents
Maximum permissible pressure (PS)	0 – 32 bar
Test pressure	35.2 bar
Permissible air humidity	> 100%
Test date	See order documents
Test medium	Dry air
Airborne noise emitted	See applicable offer document. In acc. with the standard procedure for measuring the sound pressure levels referred to in EN 13487; Annex C (normative).
Weight	See order documents

3.2 Fans

The fans' technical delivery conditions comply with DIN 24166, accuracy class 2.

Fan type	See order-related documents
Current type	Rotating or alternating current

Voltage	400 V 3~ 50 Hz or 230 V 1~ 50 Hz
Balancing quality	Q 6.3 in acc. with VDI 2060
Protective devices	<ul style="list-style-type: none">• Thermal: Thermo-contacts (temperature monitor for safeguarding against thermal overload).• Mechanical: Protective contact grille in acc. with EN 294

4 Set-up and function

The condenser consists of

- a coil consisting of pipe coils with fins, (copper tube; aluminium fin) Inlet and outlet headers (copper) and tube connections to the piping,
- a casing made of galvanized sheet steel, painted in RAL 7035, light grey.
- and – depending on the version – one or more radial fans. Two fan versions are possible here: normal and boosted (optional).

Condensers of the RVH/RVV series are intended for installation in a refrigeration system. The refrigeration system is a combination of refrigerant-carrying components and fittings connected with one another, which form a closed circuit, in which the refrigerant circulates.

The refrigerant absorbs heat at a low temperature and low pressure and evaporates (evaporator-side), and at a higher temperature and higher pressure gives off the heat again and condenses itself (condenser-side). The condensers condense the refrigerant by giving off heat to the air that is moved by fans over the dry heat exchanger surface.

The FC/HFC refrigerants R-134a, R-404A, R-407C, ... used are refrigerants of group L1/A1 (see "Residual hazards due to CFC/HFC refrigerants", page 27).

5 Fan motor

NOTICE

In the case of longer storage periods, the fans must be operated for 2 to 4 hours every month. If the unit in its installed state has not been used for a longer period of time in damp environment (e.g. outdoors), the unit must be operated once a month at full speed for at least three hours so that the bearings move and any penetrated condensate can evaporate.

NOTICE

For fans with the protection rating IP55 or higher, existing closed condensation water holes must be opened at least once every six months.

AC technology

The AC motors are protected against overheating by a thermocontact (or PTC resistor).

For motors with a thermocontact, the thermocontact must be switched in such a way that the motor cannot be powered on when the thermocontact is triggered. A locking mechanism is recommended to prevent unintentional renewed power-on.

Motors with a PTC resistor need an additional external trigger unit for the installed thermistors. A locking mechanism is recommended to prevent unintentional renewed power-on. The test voltage at the thermistors is not permitted to exceed 2.5 V or only current-limiting test devices are allowed to be used.

When using a star-delta connection, a corresponding delay must be considered.

For motors with direct starting and a connection value > 4.0 kW, an inrush current limitation (soft start using a thyristor) could be required.

If frequency converters are to be used for speed control, the following points must be considered for external rotor fans:

Between the frequency converter and fans, all-pole sine-wave filters must always be installed (sine wave-shaped output voltage; filter effect between phase to phase and phase to earth).

The frequency converters from Güntner GmbH & Co. KG are equipped with this function as a standard. Three-phase standard motors are suitable for direct operation with frequency converters.

Three-phase fan motors can be operated with a star-delta connection or with speed control. The direction of rotation must be checked. A change in the direction of rotation, if it is wrong, is made by interchanging two phases.

EC technology

Please inform yourself about general differences between EC and AC technology.

NOTICE

The fan motors have their own electronic power component. This power component is controlled by means of Güntner Motor Management (GMM). The motors can be operated using single-phase (1~, 200 - 277 V AC, 50/60 Hz) or three-phase (3~, 380 - 480 V AC, 50/60 Hz) voltage rates, depending on type. When operated without GMM, the fans should be controlled with a voltage of 0 - 10 V. Refer to the connection plans or the information on the motor terminal box for details on the electrical connection.

6 Transportation and storage

6.1 Safety

⚠ WARNING

Crushing danger with falling down!

It can slip and fall off the transporting device, causing serious injuries or death. Heavy impacts or vibrations can damage the unit.

Ensure that the assigned staff is trained for proper unloading.

Ensure that nobody is under the unit or near the loaded area during the transport.

Make sure the weight is evenly distributed. Make sure that the bulk of the weight is always on the fan side. Note the transport sticker (see "Other signs and notes on the unit or packaging", page 18).

Crane and forklift transport: Ensure that there is no snow on the unit and no wind.

Secure the unit against slipping and mechanical damage.

When transporting by crane: Attach the hooks and shackles of the load handling devices only to the points provided by the manufacturer, i.e. to the factory-mounted crane lugs. Ensure that the unit casing is not compressed by straps.

Use transport devices if necessary. Use a transport device that is suitable for the weight of the unit. For the weight of the unit, refer to the order documents (see "Set-up and other applicable documents", page 8). Do not use connection pieces and outlet headers as attachment points for lifting, pulling, fixing and climbing. This can result in leaks and subsequently leakage.

Transport the unit carefully. Particularly avoid setting the unit down hard.

6.2 Transportation and storage

NOTICE

Read and observe all transport signs on the units' packaging!

Prolonged mechanical stresses caused by uneven road surfaces and potholes and vibrations during transport by ship can cause transportation damage. Before transportation by sea or in countries with difficult transport routes, attachment parts that are likely to vibrate – in particular fans and base stands – must be removed for transportation.

- ▶ Transport the packed unit with suitable transport equipment (e.g. industrial truck with forks, crane) to the final place of installation.
- ▶ Unload the unit.

⚠ WARNING

Danger of damage to goods by falling when transporting by fork-lift!

Packed units that are not lifted with forks of appropriate length could slip and fall.

- ▶ You must use a industrial truck with forks to lift the packaged unit. The load must be as close as possible to the back of the forks and the forks must be long enough so that the pallet rests completely on the forks in width. Pay attention to the positioning information for the industrial truck with forks.

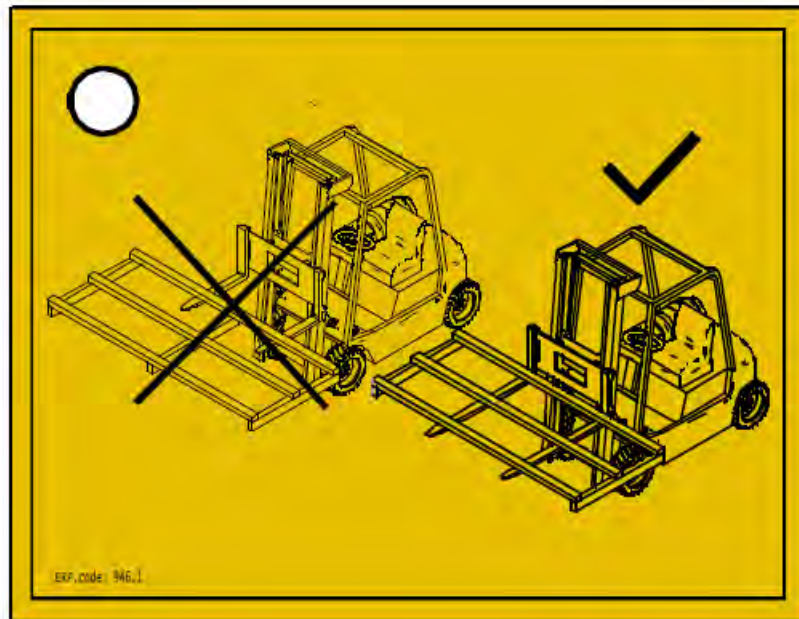

6.3 Storage before installation

NOTICE

Danger of corrosion and dirt build-up!

Moisture and dirt must not enter the unit.

- ▶ Protect the unit against dust, dirt, moisture and wetness, damage and other harmful influences. Harmful influences: see "Safety instructions for set-up and start-up", page 41
- ▶ Do not store the unit for longer than necessary. Only store the units in their original packaging until installation. Always only place packaging units of the same size on top of one another.
- ▶ Store the unit at a protected place free of dust, dirt, moisture and damage-free until its set-up (well-ventilated halls or roofed storage site).
- ▶ If the unit set-up is delayed with regard to the planned installation time: protect the unit against weather and other harmful effects and dirt and other contaminants with an appropriate cover. The unit must also be well-ventilated here.

7 Set-up and start-up

7.1 Safety

7.1.1 Safety instructions for set-up and start-up

WARNING

Risk of damage to property!

In order to avoid stray currents, heat exchanger tubes, casing parts and the like must not be used as return line when performing welding work as these load-bearing components and lifting accessories are not designed for high welding currents.

If not observed, unintended or improper current flow can damage heat exchanger pipes of the unit and lead to damage during operation.

Securely connect the insulated welding return line to the workpiece to be welded or to the pipe holder (header) directly at the welding point.

WARNING

Risk of damage to property!

To prevent damage to the heat exchangers, always connect them without force and torque. There must be no forces or moments acting on the heat exchanger at any time. Failure to observe this can result in leaks and further damage to the heat exchanger in the short and medium term.

Ensure that the outlet headers and flanges are not used as a climbing aid, e.g. during installation. They are not designed for external forces.

Ensure that no forces or moments act on the heat exchanger at any time by using suitable fixed bearings during pipe installation.

WARNING

Danger of injuries and damage to property with escaping CFC/HFC refrigerant!

In case of improper installation, there is a risk of working fluid escaping during operation of the plant, which can result in personal injury and damage to property (see "Residual hazards due to CFC/HFC refrigerants", page 27)

Follow the set-up instructions in this chapter precisely and apply extreme care!

NOTICE

Danger of damage to the system!

Foreign materials and contaminants in the working fluid circuit can impair the effectiveness or damage system components. Particularly harmful contaminants are:

- Moisture,
- Atmospheric air
- Rust
- Soot/ash/cinders
- Metal cuttings
- Unstable oils
- Dust and dirt of all kinds

Moisture in the working fluid-carrying components of the unit can result in:

- Water separation and ice formation cause faults in the switching and control fittings of the refrigeration system
- Acidification
- Ageing and decomposition of the lubricating oil for refrigerating compressors,
- corrosion.

Atmospheric air and other non-condensable gases can have the following consequences:

- Refrigerator oil oxidation
- Chemical reactions between working fluid and lubricating oil for refrigerating compressors,
- Increased condensing pressure in the system

Chemical reactions between working fluid and refrigerator oil with the absence of moisture or atmospheric air with ageing and working fluid and refrigerator oil decay can have the following consequences:

- Formation of organic and inorganic acids
- Increased compressed gas temperature in the system
- Corrosion
- Bad lubrication, increased wear and tear throughout the system or failure

Other contaminants can cause:

- Accelerated chemical processes (decomposition)
- Mechanical and electrical faults in the refrigeration system

During installation (connection of the working fluid-carrying components to the working fluid-carrying system of the plant), make absolutely sure that no dirt gets inside.

Perform the installation with extreme cleanliness.

Finish all local pipe installation work before releasing the transport excess pressure!

Do not release the transport excess pressure until immediately prior to mounting.

Only remove the sealing caps on the distribution and header pipe immediately before installation.

NOTICE

Danger of corrosion and dirt build-up!

Moisture and dirt must not enter the unit. If moisture and dirt enter the unit, there is also a risk of damage to fittings and other components of the plant.

Protect the unit against dust, contamination, moisture and wetness, damage and other harmful influences. Harmful influences are, for example:

- Mechanical: Damages caused by impacts, objects falling on or against, collisions with transport equipment, etc.
- Physical: Damages caused by close by concentrated flammable gases
- Chemical: Damages caused by contaminated atmospheres (salt, acid, chlorine, sulphur-containing, or similar)
- Thermal: Damages caused by close-by heat sources

Begin with the installation as soon as possible.

⚠ WARNING

The electrical installation may be performed only by electricians (or by expert technicians with appropriate qualifications) in compliance with the relevant VDE rules (or applicable national and international regulations) and the TCC of the EPCs!



7.1.2 System-side safety requirements

The unit is a component a system and can only be operated in conjunction with the system .

- All equipment required for operating the unit must be integrated into the switching and activation equipment (complete system) :
 - Electrics: Fans and other electrical components
 - Working fluids: valves and fittings
- The working fluid-side and electrical connections must be available on the system. The connections must be specified in the order-related documents.
- The power supply of the fans must be provided in acc. with the specifications on the type plate on the fan motors.
- A switch-off device for preventing unexpected start-up (repairs switch), which separates all active conductors from the power supply (all-pole switch-off), must be provided for the fans in acc. with EN 60204-1.
- The fans' switch-on/off device must be secured (e.g. with a padlock) to prevent uncontrolled fan start-up.
- The electrical motor, repairs switch, terminal box and switching cabinet connections must be provided in acc. with the respective connection diagrams.
- It must be possible to shut off the unit if a leak occurs.
- All security-relevant shut-off valves must be operable by persons wearing self-contained breathing apparatuses and full protective suits.
- It must be possible to activate all devices meant for diverting escaping working fluids from a safe position.

7.1.3 Customer-side safety precautions

⚠ WARNING

Danger of injuries!
 The unit contains an FC/HFC refrigerant (see "Residual hazards due to CFC/HFC refrigerants", page 27).
 The FC/HFC refrigerants that are used (R-134a, R-404A, R-407C, R-507, R-22, ...) are Group L1/A1 refrigerants classified according to flammability (L) and toxicity (A) in accordance with EU Directive 2014/68/EU for pressure equipment (Pressure Equipment Directive):

- Refrigerants that, when gaseous, are non-flammable irrelevant of their concentration in air.
- Refrigerants with a time-weighted, averaged concentration that have no adverse effects on the majority of staff that are exposed every day during a normal 8 hour working day and a 40 hour working week to this concentration, which is greater than or equal to 400 ml/m³ (400 ppm (V/V)).

There is no imminent danger for the staff. However, refrigerants of the Group L1/A1 are generally heavier than air and may flow off to rooms on a lower level. In still air there may be an increase of the ground level concentration. With high concentrations there is a danger of suffering from disordered cardiac rhythm and suffocation due to a reduced oxygen concentration, especially at ground level.

Unauthorised people must not have access to the unit. Please ensure that CFC/HFC refrigerant escaping from the unit cannot reach the interior of the building or put people at risk in any other way.

Comply with the requirements of EN 378-3 for refrigerants, filling weight and cold transfer systems.

Install the unit in accordance with EN 378-1 only in the commissioned configuration and only in a set-up room that the unit manufacturer has configured the unit for.

Install the unit in accordance with EN 378-3, section 5 in a special machine room if an explosion or a CFC/HFC refrigerant concentration of more than that permissible under EN 378-3 could endanger the work environment. Take effective protective precautions if such a spatial separation were to be required, but is not possible.

Install the electrical equipment (for the fan drive, for ventilation, for lighting and the alarm system) in the installation room, taking into account the condensation of humidity, the dripping water formation and the level of risk of FC/HFC refrigerants in accordance with EN 378-3; section 6.

Arrange CFC/HFC refrigerant detectors and alarm systems to warn of explosion or fire dangers and CFC/HFC refrigerant concentrations that are hazardous to health and for control purposes in the unit set-up room in accordance with EN 378-3; section 7.

Ensure that the device in the set-up room is not exposed to any inadmissible high temperature effects. Effectively protect the unit against heat sources or temporary high temperatures.

⚠ WARNING

Danger of environmental pollution!

- Ensure that no refrigerant enters water systems or sewage.
- Operate the facility for recovering or disposing of refrigerant so that the danger of a refrigerant or refrigerator oil emission into the environment is kept as low as possible.

7.2 Requirements as regards the place of installation

You will find the dimensions and weights in the order-related documents.

- ▶ Position the unit so that it cannot be damaged by internal traffic or transport processes.
- ▶ Enable optimum unit control and accessibility:
 - Place the unit so that it can be monitored and controlled from all sides at all times.
 - Ensure that sufficient space is provided for maintenance.
 - Ensure that all fluid-carrying components, connections and lines and all electrical connections and lines are easy to access.
 - Ensure that the tubes' identification is well visible.

7.3 Unpacking the unit

- ▶ Check scope of delivery for completeness. For the scope of delivery, refer to the order documents.
- ▶ State transport damages and/or missing parts on the delivery notes. Immediately notify the manufacturer in writing about the matter. Damaged fins can be repaired on site using a fin comb.
- ▶ The units are delivered in installation position.
- ▶ Check transport excess pressure: All units are delivered by the manufacturer with approx. 1 bar of transport excess pressure (cleaned and dehumidified air). Establish the transport excess pressure at the Schrader valve (pressure measurement). In case of unpressurised units: Immediately notify the manufacturer and note it on the delivery note. An unpressurised unit indicates a leak in the unit.

CAUTION! Risk of personal injury and damage to property due to escaping working fluid! An unpressurised unit indicates a leak due to transport damage. Escaping working fluid due to leaks in the unit can cause personal injury (see "Residual hazards due to CFC/HFC refrigerants", page 27). Do not put the unit into operation!

- ▶ Check and release the transport excess pressure (only immediately prior to mounting).
- ▶ Remove caps.

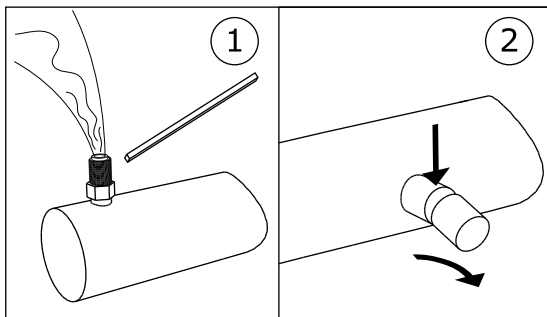

1: Check/release the transport excess pressure. 2: Remove caps.

NOTICE

Risk of corrosion and soiling!

Moisture and dirt must not enter the unit.

Protect the unit against dust, dirt, moisture and wetness, damage and other harmful influences. Harmful influences: see "Safety instructions for set-up and start-up", page 41

Begin with the installation as soon as possible.

7.4 Installation

7.4.1 System-side requirements for stress-free installation

- ▶ Prevent stresses in the unit:
 - Ensure that all fixing points have the same spacing to the fixing level.
 - Ensure that all fixing points maintain the same spacing to the fixing level under load and permanently.
- ▶ Set up and fix units as follows: Airflow must not be impaired by obstructions.

- ▶ The units must be installed on fixing points that are appropriate for the unit's weight and then bolted with fixing bolts. The operator or installer of the equipment is responsible for ensuring that the bolted connections are of an adequate strength. The following instructions must be observed when fixing the units:
 - The diameter of the mounting holes have been statically determined by the manufacturer; the fixing bolts must be adapted accordingly. When calculating the transferring bearing strength it is imperative to take into account the total weight of the unit (= structural weight + weight of pipe content + additional weight, such as water, frost, ice, dirt or similar).
 - The fixing bolts must be secured against loosening with an appropriate locking device.
 - The fixing bolts must not be overtightened or stripped.
 - All fixing bolts must be tightened equally.
- ▶ Prevent the unit from shifting in its position. Fix the unit in its position. Tighten the fixing bolts and secure them against loosening.
- ▶ Only fix the unit to the intended fixing points.

7.5 Notes on connecting the unit

WARNING

Danger of injuries and damage to property with escaping CFC/HFC refrigerant!

In case of improper installation, there is a risk of working fluid escaping during operation of the plant, which can result in personal injury and damage to property (see "Residual hazards due to CFC/HFC refrigerants", page 27).

Prevent working fluid from escaping from the unit into the environment.

- Secure all working fluid-carrying lines against mechanical damage.
- In areas that are used for internal traffic, only lay the pipelines to and from the unit with connections and fittings that cannot be removed.

Ensure that the on-site connections do not exercise any forces upon the distribution and header points. This can cause leaks on the working fluid connection points of the unit and on connection points of the on-site pipe-laying.

Ensure that:

- Release devices to prevent liquid escapes are provided and available.
- During system standstill periods, undercooled liquid is only present in the lowest possible amount in system components by minimising the number of dead end traps.
- When switching over a duty pump to a reserve pump no liquid, cold working fluid remains in the pump.

7.5.1 Connect the unit to the system

⚠ WARNING

Danger of injuries and damage to property!

Improper connection to the the system causes hazards:

- Leaks result in the escape of the FC/HFC refrigerant (see "Residual hazards due to CFC/HFC refrigerants", page 27).
- Smoking or open light can cause fires due to the presence of refrigerator oil.
- Ensure that stresses and vibrations from the system are not transferred to the unit.
- Only lay working fluid-side connections stress-free! The on-site pipeline system must be braced before connecting to the unit!
- Evacuate the unit professionally in acc. with EN 378-2.
- Smoking is not permitted at the installation site, handling open flames is prohibited. Fire extinguishing equipment and fire extinguishing agents used to protect the unit and the operating staff must comply with the requirements of EN 378-3.
- Ensure that refrigerant detectors and alarm devices to warn of fire hazards, of concentrations hazardous to health and for control purposes are installed at the place of installation in accordance with EN 378-3, section 7.

- ▶ Install the pipes in acc. with EN 378-1 and EN 378-3. Ensure here:
 - Release devices to prevent liquid escapes must be provided and available.
 - That in shutdown state under-cooled liquid is only present in the lowest possible amount in system sections – minimized number of "fluid sacks".
 - Avoid transmitting vibrations to the unit via conduits or pipes. If necessary, use vibration dampers.
 - The condensate drain pipe must run with a slight slope of 3–5°.
 - Liquid and pressure lines must always run apart and must be insulated on both sides
 - The free space around the unit must be big enough to ensure there is no danger to the unit; regular maintenance of the components must be possible, and it must also be possible to check and repair components, pipes and fittings.
 - It must be possible to shut off the unit if a leak occurs. It must be possible to activate all devices used for diverting escaping working fluids from a safe position.

7.5.2 Unit electrical connection and protection

All fans with rotating current drive can be operated via D-S switch-over with two different speeds:

- D: high speed
- S: lower speed
- ▶ Connect fan motors in acc. with motor connection wiring diagram in the motor terminal box or circuit diagram and check connection.
- ▶ Provide power supply in acc. with the specifications on the fan motor's type plate or circuit diagram:
- ▶ Protection of fan motors required: Connect thermocontacts for the motor protection and evaluate them, if available.

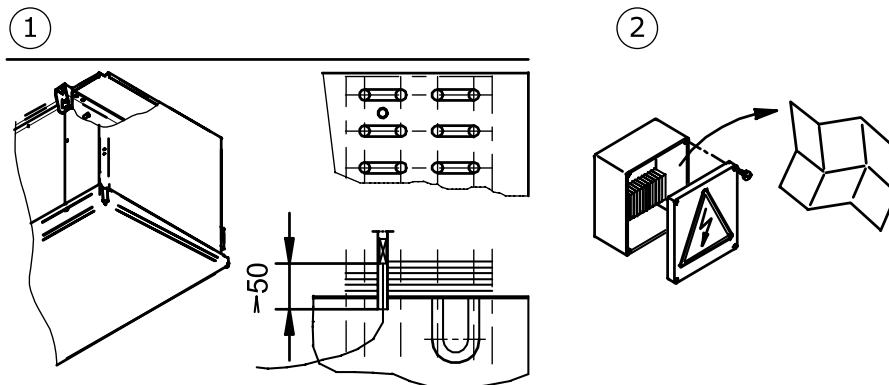

- 1 Defrost limit sensor position (if used)
 - 2 Electrics (fan motor, stamp data, connection values)
- ▶ Provide and secure all electrical lines to the connection boxes/switch cabinets acc. to EN 60204-1. Ensure compliance with the IP protection class. Observe the information in the circuit diagram. The protection class is specified in the chapter "Technical data - fans".

⚠ WARNING

Risk of damage to property! If the fuse rating is too high there is the risk of injuries to people and damage to property.

7.6 Perform acceptance test

⚠ WARNING

Danger of injuries and damage to property!

The release of the FC/HFC refrigerant can cause personal injury (see "Residual hazards due to CFC/HFC refrigerants", page 27).

Perform the following acceptance test with an expert before starting up the unit after making important changes and after a unit exchange.

- ▶ Ensure that the temperature and humidity at the place of installation correspond to the technical data (see "Technical data", page 34).
- ▶ Ensure that sufficient air can be sucked in and released.
- ▶ Ensure that the current supply is sufficient for the required energy: Compare the unit within the plant with the layouts of the plant and the connection diagrams.
- ▶ Check the unit for oscillations and vibrations that can be caused by the fans and the operation of the system. Eliminate vibrations and movements after consultation with the manufacturer or independently.
- ▶ Perform visual inspection of the structural design, the brackets and fixtures (materials, sequence, connections), the ability to operate and the arrangement of the fittings.
- ▶ Check and if necessary re-tighten all threaded connections, especially on the fans.
- ▶ Check installation of pipe connections.
- ▶ Check laying of working fluid-carrying connection pipes.
- ▶ Ensure that the unit is protected against mechanical damage.
- ▶ Ensure that the unit is protected against inadmissible heating up and cooling down.
- ▶ Check the fan blades protection.
- ▶ Ensure that optimum unit control and accessibility are guaranteed.

- Is the unit placed so that it can be monitored and controlled from all sides at all times?
- Is sufficient space provided for maintenance?
- Are all working liquid-carrying components, connections and lines and all electrical connections and lines easy to access?
- Are the tube identifications well visible?
- ▶ Check heat exchanger surfaces for dirt and clean as required (see "Clean unit", page 61).
- ▶ Perform function tests on the fans (rotation direction, power consumption, etc.).
- ▶ Check electrical connections of the fan motors for damage.
- ▶ Perform pressure test with test gas and with a test pressure of 1.1-times the permissible operating pressure: check the connection seals and detect leaks, e.g. with foaming agent, or similar.
- ▶ Check corrosion protection: Perform a visual inspection on all return bends, components and component holders that are not heat-insulated. Document and archive test results.
- ▶ Perform test run. Observe and check unit during test run, in particular for:
 - Fan smooth running (bearing noises, contact noises, imbalances, etc.).
 - Fan power consumption:
 - Leaks
- ▶ Report all defects to the manufacturer immediately. Remove defects following consultation with the manufacturer.
- ▶ Double-check the unit and the interaction of the unit with of the plant after approx. 48 operating hours, especially at the connections and the fans, and document the test result.

7.7 Test readiness for operation

- ▶ Ensure that all electrical protective measures are ready to function.
- ▶ Ensure that all working fluid-carrying connections are securely in place.
- ▶ Ensure that all electrical connections (fans) are securely in place.

7.8 Putting the unit into operation for the first time

WARNING

Danger of injuries and damage to property!

The release of the FC/HFC refrigerant can cause personal injury (see "Residual hazards due to CFC/HFC refrigerants", page 27).

You can put the unit into operation, only when:

- The unit has been properly mounted and connected (see "Installation", page 46),
- You have performed a complete acceptance test (see "Perform acceptance test", page 49),
- You have checked the unit's readiness for operation (see "Test readiness for operation", page 50) and
- All safety precautions (see "Safety", page 41) have been taken.

Follow the instructions manual of the system!

Contact the manufacturer immediately if you want to operate the unit under different operating conditions as those defined in the order-related offer documents.

- ▶ Switch on the system including of the electrical system (see operating instructions of the system).
- ▶ Activate the unit:
 - Open the valves on the supply and drain side plant
 - Activate fans
- ▶ Wait until the operating point is reached. Once the operating point is reached, the unit is ready to operate (see instructions manual for the system).

Parameters for setting the operating point, see order-related offer documents.

Operating point:

- Condensation temperature
- Airflow volume
- Air inlet temperature
- Relative air humidity

To ensure the specified operating point is complied with the actuators for the operating point setting must be secured against unauthorized access (e.g. by sealing, screwing on caps, removing hand wheels, etc.).

8 Operation

8.1 Safety

⚠ WARNING

Risk of damage to property!



To prevent damage to the heat exchangers, always connect them without force and torque. There must be no forces or moments acting on the heat exchanger at any time. Failure to observe this can result in leaks and further damage to the heat exchanger in the short and medium term. Ensure that the outlet headers and flanges are not used as a climbing aid, e.g. during installation. They are not designed for external forces. Ensure that no forces or moments act on the heat exchanger at any time by using suitable fixed bearings during pipe installation.

⚠ WARNING

Danger of cutting off, danger of pulling in!



On the rotating fan blades, there is a danger of fingers being cut off, hands being injured and loose parts such as hair, necklaces and parts of clothing being pulled in. Do not operate the fans without protection guards!

⚠ WARNING

Risk of burns!



There is a risk of burns when touching parts of the unit (see "Thermal residual hazards", page 27). Do not touch any parts of the unit without protective gloves if the unit is in operation or has not yet cooled down to ambient temperature after operation.



8.2 Putting the unit into operation

NOTICE

To prevent corrosion caused by stagnant water, units with water as working fluid must be put into operation within two weeks after filling.

To operate the unit, the refrigerating plant including the electrical system must be in operation. Commission the unit by opening the respective valves on the inlet and outlet side of the refrigerating plant, and by connecting it to the electrical system as follows (see operating instructions of the refrigerating plant):

- ▶ Ensure that a professional equipotential bonding has been performed
- ▶ Switch on the electrical system
- ▶ Open working fluid-carrying lines
- ▶ Switch on fans

8.3 Taking the unit out of operation

The units are system components of a refrigerating system. The unit is taken out of operation by switching off the refrigeration system in acc. with the refrigeration system instructions manual. To do this, the working fluid-carrying lines of the refrigeration system and the fans of the electrical system must be shut off (see refrigeration system instructions manual):

- ▶ Switch fans off
- ▶ Switch electrical system off
- ▶ Close working fluid-carrying lines
- ▶ **NOTE! When shut down consider max. operating pressure! If necessary, take precautions to ensure that it cannot be exceeded, or drain the device.**

NOTICE

With shutdown times of a month or longer put the fans into operation for approx. 2-4 hours a month to maintain their functionality.

8.3.1 Shutdown, dismantling and disposal

Safety

⚠ DANGER



Risk of injuries owing to electrical voltage!

Direct and indirect contact with live cables can cause serious injuries or death.

- Have the work carried out only by a qualified electrician.
- Work should be carried out in accordance with local regulations, e.g. DIN VDE 0105/EN 50110.



NOTICE

See "Safety"

Procedure

- ▶ Disconnect all systems from the power supply.
- ▶ Make sure that the system is drained.
- ▶ Follow the steps shown in chapter "Installation" in reverse order.
- ▶ Dispose of the materials separately according to the applicable laws and regulations. The pads can be disposed of with the residual waste.

8.4 Shutting the unit down

⚠ WARNING

Danger of injuries and damage to property!

Escaping FC/HFC refrigerants can cause personal injury (see "Residual hazards due to CFC/HFC refrigerants", page 27 and "Residual hazards caused by pressurised parts", page 29).

Ensure that the maximum operating pressure is not exceeded after the shutdown either!

NOTICE

Danger of corrosion and dirt build-up!

Moisture and dirt must not enter the unit.

Protect the unit against dust, dirt, moisture and wetness, damage and other harmful influences (see "Safety instructions for set-up and start-up", page 41).

With shutdown times of a month or longer put the fans into operation for approx. 2-4 hours a month to maintain their functionality.

- ▶ Take the unit out of operation (see "Taking the unit out of operation", page 53)
- ▶ Secure the unit:
 - When shutdown consider max. operating pressure (see "Technical data", page 34)! If necessary, take precautions so that it cannot be exceeded.
 - Secure the fan motor drives against switching on again
 - Secure working fluid-carrying lines against pressurizing with working fluid.
 - Secure against harmful influences at the place of installation or intermediate storage location (see "Safety instructions for set-up and start-up", page 41) so that the components of the unit are kept in good condition and the intended use and usability of the unit are maintained. To this end, appropriate storage conditions must be provided (see "Storage before installation", page 40) and preventive corrosion protection measures, regular checks of the functionality of the fans and regular inspections of the decommissioned unit must be carried out.
- ▶ Siphon off the unit: Completely release working fluid and, if applicable, refrigerator oil (see "Residual hazards with disposal", page 32 instructions manual).

8.5 Putting the unit into operation after a shutdown

The unit must be put back into operation in acc. with the system-specific set-up in acc. with the instructions manual of the system as follows:

- ▶ Test the unit's readiness for operation (see "Test readiness for operation", page 50). Perform pressure test and visual inspection for corrosion protection.
NOTE! The pressure test with recommissioning must only be carried out with appropriate media at appropriate test pressure.
- ▶ Put the unit into operation (see "Putting the unit into operation", page 52)

8.6 Changing the unit over to another working fluid

▲ WARNING

Danger of injuries and damage to property!

Operating the unit with a different working fluid without the prior consent of the manufacturer can result in significant dangers (see "Improper use", page 23).

The unit must not be changed over to another working fluid without prior written consent of Güntner GmbH & Co. KG!

- ▶ Ensure that the unit manufacturer has agreed to the changeover.
- ▶ Ensure that the unit is filled with the correct working fluid. Ensure that all materials used in the unit are compatible with the new working fluid.
- ▶ Ensure that the permissible pressure is not exceeded.
- ▶ Check that the new working fluid can be used without requiring a new test certificate for the unit. Ensure that classification is complied with.
- ▶ The safety device for the unit must be swapped out or reset.
- ▶ Mixtures with residues of working fluid and oil, for example, must be prevented.
- ▶ All information concerning the new working fluid must be changed accordingly.
- ▶ Change the complete documentation including these instructions and the instructions manual of the system accordingly.
- ▶ Perform an acceptance test (see "Perform acceptance test", page 49).

9 Troubleshooting

9.1 Safety

⚠ WARNING
<p>Danger of injuries and damage to property!</p> <p>Faults not described in these instructions may only be rectified by Güntner GmbH & Co. KG. Contact the Güntner hotline.</p> <p>Faults that are described in these instructions must only be removed by appropriately trained personnel (see "Personnel, care requirements", page 22).</p> <p>With faults that occur during the operation, monitoring and maintenance of the complete system, inform Güntner GmbH & Co. KG immediately.</p>

9.2 Service

Office hours

Tel. +49 8141 242-473
 Fax. +49 8141 242-422
 E-mail: service@guentner.com
 Mon-Thurs: 7.30 am - 5 pm
 Fri: 7:30 am - 13:00

9.3 Troubleshooting table

Fault	Possible cause(s)	Remedy
Fan motor not running	Power supply interrupted	Restore power supply
	Fan blade stuck	Enable fan to rotate freely
Bearing noises	Defective fan motor	Renew bearing or fan motor
Unit vibrating	Defective fan blades	Change fan blades
	Loose fan fixture	Tighten fixtures
Unit capacity not achieved	Coil is very dirty on the air side	Clean the coil
	Fans not running properly or down	Repair, exchange fans
	Working fluid pressurising defective (temperature and quantity insufficient)	Set working fluid pressurising values (temperature and quantity) to reference values.
Working fluid escaping	Working fluid-carrying components of the unit are leaking	Switch off working fluid feed and fans, close leak

10 Maintenance

10.1 Safety

10.1.1 Before starting all maintenance

⚠ WARNING

Risk of personal injury and damage to property due to escaping working fluid (see "Residual hazards due to CFC/HFC refrigerants", page 27).

Perform the following safety measures before beginning all maintenance work:

- Siphon off the coil (heat exchanger) of the unit
- Clean and blow out the coil (heat exchanger) of the unit.

⚠ CAUTION

Risk of injury caused by corrosion!

The unit is exposed to corrosive environment for a long time. Due to the onset of corrosion, the unit loses stability and is no longer suitable for lifting by crane or industrial truck with forks and endangers bystanders.

Check load-bearing components, fasteners and fans of the unit for corrosion damage and load-bearing capacity regularly and replace them, if necessary.

Check all fixing devices, especially of the lifting accessories (e.g. crane lug screws/bolts), for lifting capacity and structural integrity, and replace them if necessary.

10.1.2 With all maintenance work

⚠ **WARNING**

Danger of injuries and damage to property with escaping CFC/HFC refrigerant! Escaping refrigerant with leaks on the evaporator can cause the following hazard situations and injuries:



Warning against explosion-risk and fire-risk substances in the set-up room! Unintentionally carried in oil residues can ignite.

- Ensure that there is no unintentionally carried in oil in the set-up room.
- Keep the risk area free of direct and indirect ignition sources.
- Before releasing for maintenance obtain the required approvals for work for the unit that can involve ignition sources (e.g. grinding, welding, soldering, etc.).
- With all work involving ignition sources (e.g. grinding, welding, soldering, etc.) in the work area, keep suitable fire extinguishing equipment that meets the requirements of EN 378-3 at hand.
- Do not bring any open flames or hot gases (e.g. candles, matches, welding beads, welding sparks, glowing cinders or tobacco) into the set-up room.
- Ensure that there are no warmed up or hot surfaces (e.g. heaters, hot-plates, bulbs, motor housings) in the set-up room.
- Ensure that no frictional heat develops in the set-up room (e.g. overheated stores).



Warns against health-endangering irritants in the set-up room! CFC/HFC refrigerant under defervescence still present can evaporate. Inhalation of refrigerant vapour causes harmful to health irritations and lack of oxygen.

- Escaping refrigerant vapour and escaping refrigerant liquid must not reach adjacent rooms, staircases, yards, passages or drainage systems.
- Use respiratory protection.
- Use a self-contained breathing apparatus for repair work in areas with high HF/HFC concentrations in the ambient air.
- Ensure the set-up room is well ventilated.
- Divert escaped refrigerant vapour and escaped refrigerant liquid safely.



Warns against cold! Still present CFC/HFC refrigerant under defervescence has a temperature of 0 °C. Contact with refrigerant under defervescence caused by spraying causes frostbite.

- Use eye protection!



- Use hand protection!



- Ensure that the unit in question is pressure-free before maintenance work begins or the working fluid is sucked up from the unit in question.
- Power off the electrical system and secure it against unintentional switching on again.
- Separate the unit to be maintained from the refrigeration system and secure it.

NOTICE



Danger of damage to property!
When working on the air inlet and air outlet feeds of the fans and the coil (heat exchanger), objects can get into the fans and cause malfunctions and damage to the components.

- Power off the fans before beginning maintenance work and secure them against switching on again.
- After the work has finished do not allow any objects to get back into the inlet and outlet feeds of the fans or the set-up room.

10.1.3 After all maintenance work

⚠ WARNING

Risk of personal injury and damage to property due to escaping FC/HFC refrigerant (see "Residual hazards due to CFC/HFC refrigerants", page 27)!

Perform the following safety measures after finishing all maintenance work:

- Ensure the switching and activation devices, the measuring and display devices and the safety devices function properly.
- Ensure the working fluid fittings are functioning.
- Ensure that the swivel fan units (optional) and the hinged side covers are fixed in their original position and secured against unintentional or unauthorised opening.
- Check the identification of the pipelines and ensure this is visible and legible.
- Check the fixing and corrosion protection of the components in question.
- Ensure that the electrical connections (e.g. fans) are functioning.
- Ensure that the temperature and humidity at the place of installation correspond to the technical data.
- Perform a pressure test and a leak tightness test (see instructions manual of the system).
- Perform an acceptance test (see "Perform acceptance test", page 49)
- Perform a pressure test (see instructions manual of the system).

10.2 Inspection and maintenance plan

The checks to be performed are listed in the following sections as time-scaled checklists.

The following applies to the unit as a whole:

Measure	Method	Interval
Remove frost and perform partial cleaning	Mechanical	As required (visual inspection)
Perform complete cleaning	Warm water or environmentally safe cleaning agent that is compatible with the unit's materials	As required (visual inspection)
Check for leaks/leakage		Every 6 months
Check corrosion protection		Every 6 months

Measure	Method	Interval
Check fastenings and load-bearing elements (e.g. crane lug screws/bolts) for corrosion and lifting capacity and structural integrity respectively; replace them if necessary	Mechanical	Every 12 months

10.2.1 Fans

The manufacturer's operating specifications take priority for this component. The Güntner GmbH & Co. KG recommends proceeding in accordance with the following inspection and maintenance plan:

d = daily, w = weekly, m = monthly, y = yearly				
Work to be performed	d	w	m	y
Check the fans for dirt build-ups. • With dirt build-ups: Clean fans (see "Clean unit", page 61).				X*
Check the fan drive for smooth running. • Vibrations on the unit: remove imbalances • Where required, tighten and correct blade fixtures and blade settings				X*
Fan bearing: Running sound and smoothness changes • Replace fan				X*
Fan motor: Is a new bearing due? • Replace fan				X*
Fan wheel: corrosion on bolts (with threaded blades) • Replace fan				X*
Fan blades: Corrosion or damage on blades • Replace fan				X*

*) Recommended: every six months

10.2.2 Coil of the unit (heat exchanger)

⚠ WARNING

Risk of personal injury and damage to property due to escaping FC/HFC refrigerant (see "Residual hazards due to CFC/HFC refrigerants", page 27)!

d = daily, w = weekly, m = monthly, y = yearly				
Work to be performed	d	w	m	y
Check the coil for dirt accumulation. • In the event of dirt accumulation: Clean the coil (see "Clean unit", page 61).				X*
Check the coil for general condition				X*

d = daily, w = weekly, m = monthly, y = yearly				
Work to be performed	d	w	m	y
• Damage found: Repair damage				
Check the coil for the operating point (see "Operation", page 52) • If change in fan capacity found: Restore required system-side conditions . • If change in surface temperatures found: Restore required system-side conditions .				X*
Check the coil and connections for leak tightness. • Repair the unit sections affected (see "Remove leaks", page 61).				X*
Check the coil for working fluid pressurising. • Restore required system-side conditions.				X
Check the coil for corrosion. • Corrosion or damage on core tubes, fins, support structures, tube connections, fixtures: repair unit sections affected.				X*

*) Recommended: every six months

10.3 Maintenance work

10.3.1 Remove leaks

⚠ WARNING

Risk of personal injury due to FC/HFC refrigerant (see "Residual hazards due to CFC/HFC refrigerants", page 27)!

- Have leaks removed as quickly as possible by an expert.
- Do not fill with a working fluid other than that specified in acc. with the order-related offer documents!
- Only put the unit back into operation when all leaks have been repaired.

► Perform all work including pressure, acceptance and functional test (see "Perform acceptance test", page 49 and "Test readiness for operation", page 50).

10.4 Clean unit

10.4.1 General

The following applies for cleaning: The operator must ensure that the cleaning agents are environmental friendly and compatible for the materials in the system. Harmful to the environment substances, e.g. acid-forming, are forbidden.

ATTENTION

If cleaning agents are used in cold stores, it must be ensured that they will not corrode the cooler's materials.

- ▶ Clean casing by rinsing with warm water (approx. +25°C) and/or with environmentally friendly cleaning agents.
- ▶ Rinse the casing thoroughly with warm water after using cleaning agents. The unit must be free of cleaning agents to prevent corrosion.
- ▶ Allow casing to dry completely.
- ▶ Check working fluid-side and electrical connections (see "Test readiness for operation", page 50 instructions manual).

10.4.2 clean the coil

- ▶ Drain the unit (see operating instructions of the plant).
- ▶ Shut off the unit (see operating instructions of the plant).
- ▶ Completely disconnect the fans (see operating instructions of the plant).
- ▶ Clean the coil (heat exchanger) with one of the following procedures:
 - Cleaning with compressed air (see "Cleaning with compressed air", page 62)
 - Hydraulic cleaning (see "Hydraulic cleaning", page 62)

⚠ CAUTION

Risk of damage to property!

The fins can be damaged with too high a pressure, too small a distance or a cleaning jet that hits the fins at an angle. Mechanical cleaning with hard objects (e.g. steel brushes, screw drivers, or similar) damages the heat exchanger.

- Use a pressure of max. 30 bar for hydraulic cleaning and max. 80 bar for cleaning with compressed air!
- Maintain a minimum distance from the fins of 200 mm!
- Always aim the jet vertically (max. ±5 degree deviation) at the fins!
- Do not use any hard objects when cleaning!

- ▶ Switch on the fans (see operating instructions of the plant).
- ▶ Open the liquid side (see operating instructions of the plant).
- ▶ Open the supply side (see operating instructions of the plant).

10.4.2.1 Cleaning with compressed air

- ▶ Blast heat exchanger with compressed air (max. 80 bar pressure) to remove dirt and contaminants.
NOTE! Hold the jet of the compressed air cleaner vertically with respect to the heat exchanger (max. deviation of ±5 degrees) to prevent fins bending.

10.4.2.2 Hydraulic cleaning

⚠ WARNING



Warns against dangerous electrical voltage!

Direct and indirect contact with voltage-carrying parts of motors and electrical lines can cause serious injuries or death. Water and cleaning agents conduct electricity.

- When working with water or steam jets, power off the fans and secure them against switching on again.

NOTICE

Danger of damage to property!

Water or steam jets can damage fans, electrical lines or other components.

- Ensure that electrical connections and motors as well as components and stored goods at the place of installation are not hit by water or steam jets. Cover them if necessary.
- ▶ Always remove heavier damp or greasy dirt against the airflow direction, using a high-pressure water jet (max. 30 bar pressure) or a steam pressure jet (max. 30 bar pressure). In either case, use a flat spray nozzle (distance of at least 200 mm) and, if required, neutral cleaning agents. Always direct the jet at right angles to the fins (max. deviation of ± 5 degrees). Please note:
 - With oily and greasy dirt it helps to add a cleaning agent to the water.
 - When using chemical cleaning agents, ensure that they do not attack the surfaces of the unit. After cleaning, the unit must be rinsed with warm water so that it is free of cleaning agents.
 - Cleaning should be done from inside to the outside (but always opposing the dirt on-set) and from top to bottom, so that the dirt can be removed without returning.
 - Hold the jet of the compressed air cleaner vertical to the coil (max. deviation of ± 5 degrees) to prevent the fins from bending.

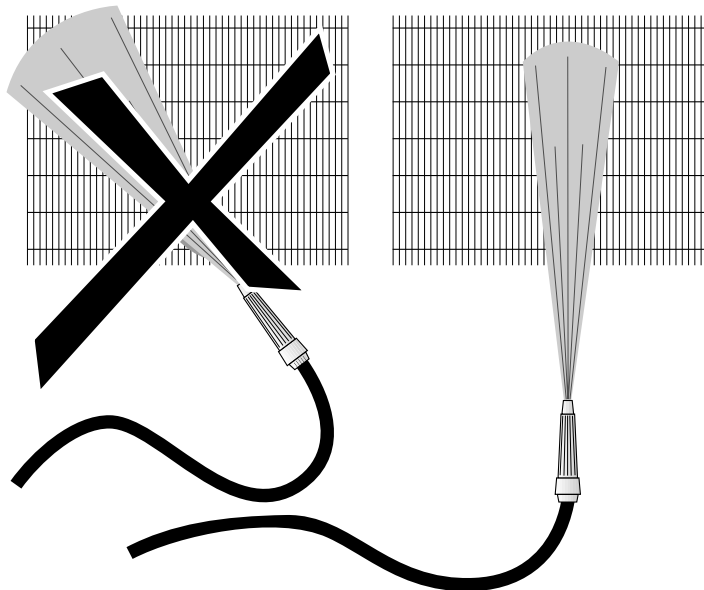

- ▶ Continue cleaning until all dirt has been removed.

10.4.3 Cleaning fans

WARNING

Danger of cutting off, pulling in!

There is a danger of cutting off fingers on the rotating fan blades, injury hazard for the hands and pulling in danger for loose elements such as hair, necklaces or clothing parts.

- Power off the unit before you begin maintenance work. Secure the unit against unintentional switching on again by removing the electric fuses for the unit. Secure the unit with a suitable warning sign referring to unintentional switching on.
- Put fans and guard grilles that were removed or opened for maintenance back into their original status without fail before you put the unit back into operation!

Dirt deposits on the fans and the fan protection grilles must be removed regularly because they can lead to imbalances or capacity loss or even destroy the fans. The fan motors themselves are maintenance-free.

- ▶ Power off the unit and secure it against unintentional switching on.
- ▶ Clean fans with one of the following procedures:
 - NOTE! Danger of damage to property! Mechanical cleaning with hard objects (e.g. steel brushes, screw drivers, or similar) damages the fan. Forbidden!**
 - Cleaning with compressed air: Blow fans with compressed air (max. 10 bar pressure; min. distance 200 mm) to remove dirt and contaminants. Continue cleaning until all dirt has been removed.
 - Cleaning with compressed air and brushes: Remove dry dust or dirt with a brush, a hand brush or with compressed air (max. 10 bar pressure, min. distance of 200 mm) or with a powerful industrial vacuum cleaner. Ensure here: use soft brushes (no steel brushes or similar)! Continue cleaning until all dirt has been removed.
- ▶ Mount protection grilles, streamers or air outlet connectors (if installed)
- ▶ Switch unit on

11 Plans/diagrams

11.1 Electrics documentation

11.1.1 Fan motor connection diagram

See motor terminal box cover inside on the fan.